

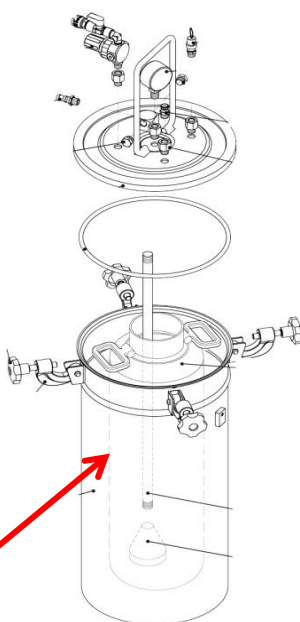

# SURVENÕU

## PZ®9020 / 15 L

1  
2

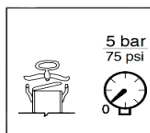
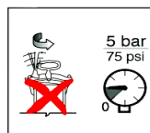
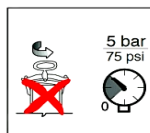
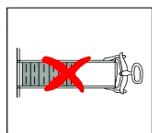

- - NB! survenõul on sisemine plastämber
- - maht 15 L
- - maks rõhk 5 bar, kaitseklapp
- - [- 6 000 - 12 000 mPas / @ 20°C](#)
- - kasutusala: liimid, õlid, tööstuslikud vedelikud

Ainult meilt tellides! [ei ole standardvarustuses]:

- - manomeetriga rõhuregulaator
- - sisendmagistraalil voolikukuusk

■ - saada päring oma kontaktandmetega:



**PAKARTE OÜ**  
 Mobiil: 5656 9482  
[pakarte@pakarte.com](mailto:pakarte@pakarte.com)  
[www.pakarte.com](http://www.pakarte.com)

22

**PZ9020**

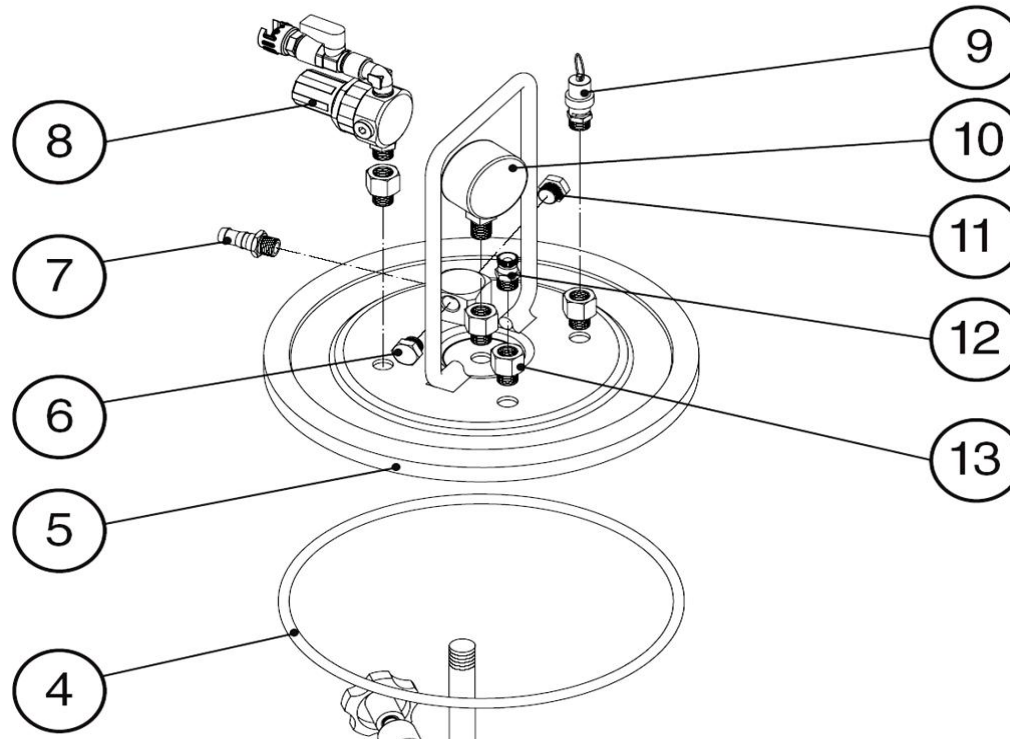
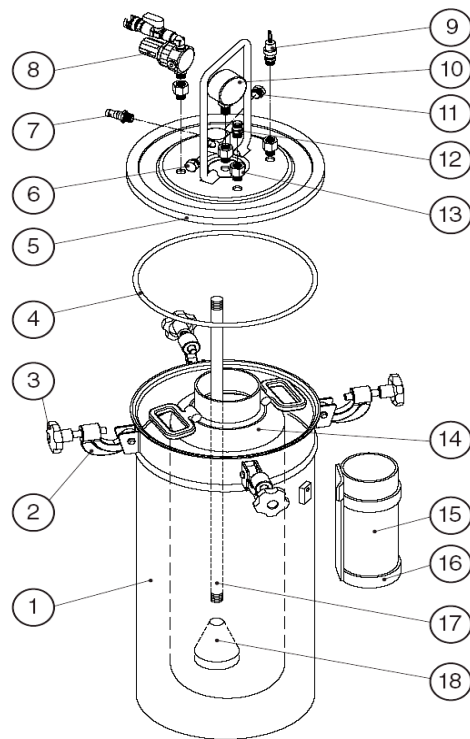

①	10049
②	10151
③	10152
④	10153
⑤	10154

⑥	10034
⑦	10035
⑧	10157
⑨	10033
⑩	10039

⑪	10034
⑫	10161
⑬	10044
⑭	0187
⑮	0001

⑯	9991
⑰	10342
⑱	10043



**PAKARTE OÜ**  
 Telefon 656 3312  
 Mobil 5656 9482  
 pakarte@pakarte.com  
 www.pakarte.com