

PAKARTE

Operating manual for extrusion valve MMDV/MV LV/KV

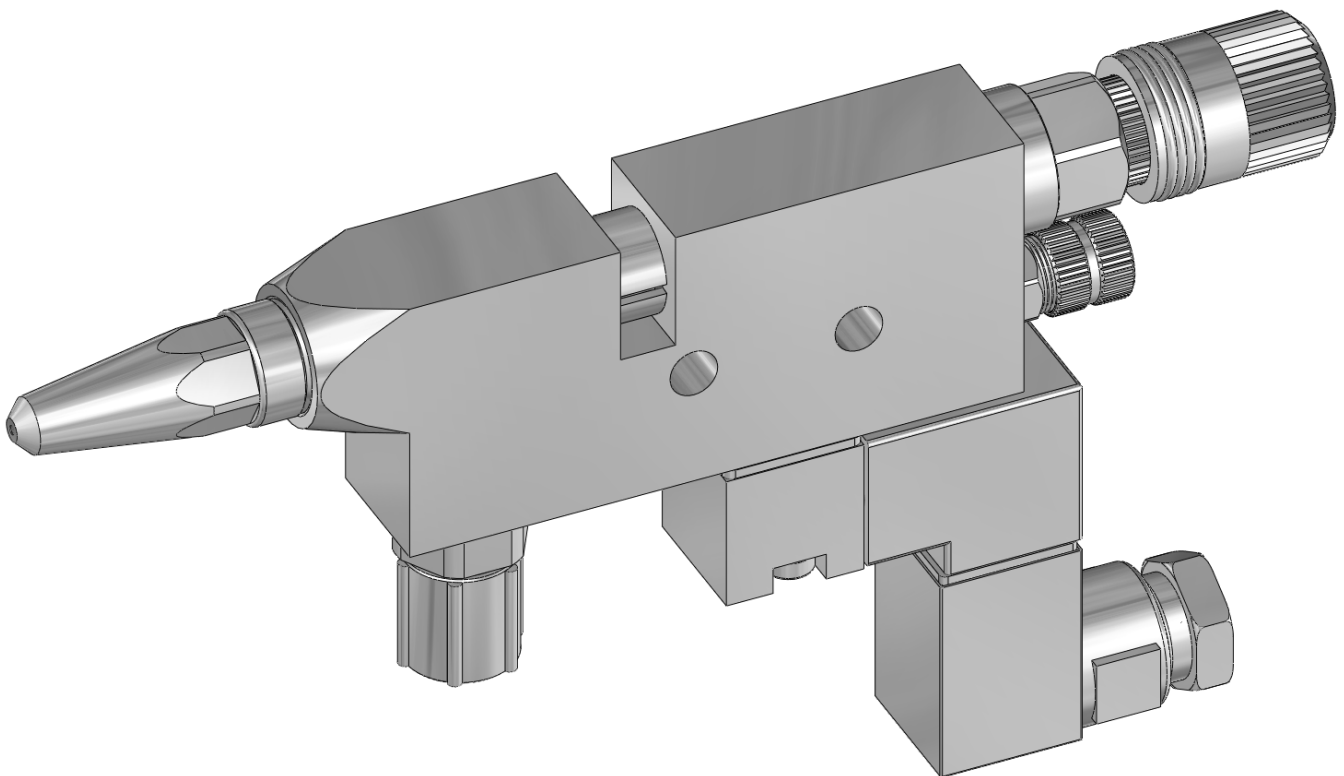

DISTRIBUTOR IN BALTICS:
PAKARTE LLC
Phone+372 5656 9482
pakarte@pakarte.com
www.pakarte.com

Read this manual carefully before installing, operating or servicing this equipment.
Keep always handy for further use.

ALFRED SCHÜTZE Apparatebau GmbH
- Spritztechnik – Spraytechnology -
Zeppelinstraße 2, 28844 Weyhe-Dreye – Germany;
Tel.: 0049 (0)421 / 43510-0; Fax: 0049 (0)421 / 43510-43
Internet: <http://www.schuetze-gmbh.de>
E-Mail: info@schuetze-gmbh.de

Distributor in Baltic: Lithuania, Latvia, Estonia
PAKARTE.COM (located in Estonia)
e-mail: pakarte@pakarte.com

Introducion

The extrusion valves of series **MMDV/MV LV/KV** are very fast acting valves for continuous or intermitted use. They are suitable for the application of glues, adhesives, oils and sealing compounds. The extreme short control air distance, reached through the directly mounted solenoid valve, gives this valve very fast and exact needle intermission cycles.

With the long nozzles (LV) the valves can be sloped to each other such to achieve narrow nozzle distances. Depending on nozzle dimension and material pressure, fluids of different viscosities can be applied. Extrusion valves are precision tools. Always keep clean and observe minimum instructions to maintain a long useful life of the valve.

1 Safety

These Operating/Installation Instructions are intended as an important source of information and reference material for personnel for the installation and operation of the device. Their purpose is to facilitate safe and proper operation of the device.

In addition to the general safety instructions in this chapter, the other chapters in these Operating/Installation Instructions give specific safety instructions where necessary. These are identified by symbols. It is essential that signs and symbols on the device itself, such as direction-of-rotation arrows, operating signs, etc., be observed. They may not be removed and must be kept in a fully legible condition.

Personnel can only be best protected against hazards and the safe, normal operation of the device can only be guaranteed if all safety instructions are observed.

First, however, one must take note of the safety concerns to be aware of when installing, operating and maintaining the device. When reading the Operating Instructions, therefore, one must begin with the first chapter "Safety". The subsequent chapters focus on other information for the personnel.

To prevent operating errors, these Operating/Installation Instructions must be kept next to the device where personnel can access them at any time. It is essential that the accident prevention regulations and the general safety provisions be adhered to when operating the device.

NOTICE!

The illustrations in these instructions may differ slightly from the actual version of the device.

1.1 General

The device has been manufactured in accordance with the latest principles of engineering and is safe to operate.

However, this device may present hazards if used by personnel who are not properly trained or if used incorrectly or not as intended.

Everyone charged with the setting up, putting into operation, operation, cleaning, servicing and repair of the device must have read and understood the Operating/Installation Instructions before beginning work on the device. This applies even if a person has already worked with an identical or similar device or was trained by the manufacturer.

It is essential to take note of the content of the Operating/Installation Instructions in order to protect personnel against hazards as well as to prevent errors and therefore to operate the device safely and normally.

To prevent hazards and to ensure optimal performance, the device may not be modified or converted, unless expressly authorised by the manufacturer.

All safety signs and operating signs on the machine must be kept in a legible condition at all times. Damaged or illegible signs must be replaced immediately.

The set values and ranges specified in the Operating/Installation Instructions must be adhered to.

It is recommended that the user obtain written confirmation from personnel that they have taken note of the content of the Operating/Installation Instructions.

1.2 Explanation of the symbols

Important signs, like safety instructions, are identified by corresponding symbols. It is essential to heed these signs in order to prevent accidents and damage to the device.



WARNING! Risk of injury!

This symbol identifies all safety instructions in these Operating/Installation Instructions, the failure to observe which presents a risk of injury or death. Carefully observe these work safety instructions and exercise particular caution when you see these signs.



IMPORTANT!

This symbol identifies all safety instructions in these Operating/Installation Instructions which must be observed because failure to do so could result in damage to and/or malfunction of the device.



NOTICE!

The notice symbol brings attention to tips and other useful information in these Operating/Installation Instructions. All notices should be observed in the interests of effective device operation.

1.3 Intended use

The safe operation of the device can only be guaranteed if the device is used as intended in accordance with the information contained in the Operating/Installation Instructions.

The extrusion valve **MMDV/MV KV LV** is a needle valve for applying sprayable materials either continuously or intermittently.

Under no circumstances may aggressive materials such as acids, alkalis, cleaning agents, chemicals, poisons, highly flammable and similar substances or gases be used! Consult the manufacturer if you have any doubt as to whether a material is suitable for use.

Intended use also includes correct adherence to the Installation, Operating, Servicing and Cleaning Instructions.

Any use of the device above and beyond this and/or use of the device for another purpose is prohibited and is considered improper use! Claims of any kind against the manufacturer and/or its authorised agents for loss resulting from improper use of the device are excluded. The user is solely responsible for all loss resulting from improper use.

The device is used in a plant and does not have a dedicated controller. During operation no operating personnel is required. The user must ensure, by installing appropriate safety equipment, that the device can be shut down as soon as a hazardous situation or fault arises.

1.4 User's responsibilities

The Operating/Installation Instructions must be kept next to the device where installation, operating, servicing and cleaning personnel can access them at any time.

The device may not be operated unless it is in a perfect technical and safe operating condition. All safety equipment must be accessible at all times and its error-free function must be checked regularly. The work safety information relates to the European Union regulations valid at the time the device was manufactured. Over the entire period of use of the device, the user is obliged to ensure compliance of the stated work safety measures with the latest regulations and observe new provisions. Outside the European Union, the work safety legislation and regional provisions in the country of use must be observed.

In addition to the work safety instructions in these Operating/Installation Instructions the standard safety and accident prevention regulations applicable to the field of application of the device as well as the applicable environmental provisions must be observed and adhered to.

The user and the personnel authorised by it are responsible for the normal operation of the device as well as for clear assignment of responsibilities for installation, operation, servicing and cleaning of the device.

The information contained in the Operation/Installation Instructions must be followed in full and without reservation!

The user must also ensure that

- other hazards that arise from the special working conditions at the place of use of the device are identified in a hazard analysis pursuant to § 5 Occupational Health and Safety Act (Arbeitsschutzgesetz)
- all further instructions and safety instructions that arise from the hazard analysis of the workstations on the device be summarised in operating instructions pursuant to § 6 Work Equipment Ordinance (Arbeitsmittelbenutzungsverordnung).

1.5 Operating personnel

The device may only be operated and maintained by authorised, trained and instructed personnel. This personnel must have received special instruction about hazards that arise.

A person who has been briefed on and, if necessary, trained in his/her assigned duties and the potential hazards in the event of improper behaviour and has been informed of the necessary safety equipment and safety measures is considered an instructed person.

A person who is able to assess the work assigned to him/her and identify potential hazards on the basis of her/her professional education/training, knowledge and experience, and knowledge of the relevant regulations is considered a qualified person.

If the personnel does not have the requisite knowledge, they must be given appropriate training.

The responsibilities for operation and maintenance must be clearly defined and adhered to, so that, in the interests of safety, there is no uncertainty about who is responsible.

The device may only be operated and maintained by persons who can be expected to do their work reliably. Persons must refrain from working in any way that compromises the safety of persons, the environment or the device.

Persons under the influence of drugs, alcohol or medication which affects the reflexes **may not do any** work on the device.

When selecting personnel, the youth employment protection laws of the respective country and any job-related laws based thereon must be observed in relation to the minimum age.

The operator must also ensure that no unauthorised persons work on the device. Unauthorised persons such as visitors, etc., may not touch the device. They must keep an adequate safe distance.

The operator is obliged to report to the user immediately any changes in the device affecting safety.

1.6 Work safety





Danger to persons and/or the device can be prevented by following the instructions on work safety.

Failure to observe these instructions can present a hazard of a mechanical or electrical nature or as a result of device failure to persons and objects.

Failure to observe the safety provisions voids any claims for damages.

1.7 Personal protection equipment

The following must always be worn when working on the device:

-  Close-fitting work clothing (low tear strength, no wide sleeves, no rings or other jewellery, etc.)
-  Goggles
to protect the eyes against airborne items and fluids
-  Protective gloves
to protect the skin against friction, abrasions, aggressive materials, punctures and deep injuries to the hands.
-  Ear protection
to protect against hearing damage when the sound pressure level is above 80 dB (A)
-  Safety shoes
to protect against heavy falling items and slipping on slippery surfaces

1.8 Hazards presented by the device

This device underwent a hazard analysis. The construction and design of the product based on this analysis is state-of-the-art.

However, an element of risk remains!

The device produces a strong jet of fluid.



WARNING! Risk of injury!

The device sprays out high-pressure fluids. Wear personal protection equipment when working on the device!

Note when installing the device in a machine or plant:

The device must be installed in a machine or plant in such a way that the spraying out of high-pressure fluids during operation does not present a hazard to persons. Safety equipment must be used if necessary. Incorporate safety instructions into the Operating/Installation Instructions.

Depending on the working environment, the use of the device can be accompanied by loud noises.



WARNING! Risk of hearing damage!
Hearing damage may result from the volume of and length of exposure to noise.
Wear ear protection when working on the device!

Note when installing the device in a machine or plant:

The device must be installed in a machine or plant in such a way that loud noises during operation and the interference with acoustic signals in the vicinity do not present a hazard to persons. Use safety equipment if necessary. Incorporate safety instructions into the Operating/Installation Instructions.

The device is supported by pneumatic components.



WARNING!
The pneumatic energies can cause severe injury. If a component is damaged, high-pressure materials can spray out and cause injury and property damage!
Therefore:

- Before beginning work on the pneumatic system, first depressurise the device.
- Do not remove safety equipment or disable it by modification.
- Do not set the pressures higher than the values specified in the Operating/Installation Instructions.

The device has sharp edges and pointed corners.



WARNING! Risk of injury!
Housing parts with sharp edges and pointed corners can cause skin abrasions. Wear protective gloves when working on the device!

1.9 What to do in case of danger or accident

In case of danger or accident the device must be stopped by activating an EMERGENCY-OFF switch immediately. This can also be done by opening a guard door or shield fitted with safety switches, which trigger the EMERGENCY-OFF function when opened.

Safety equipment with EMERGENCY-OFF function must only be activated in an emergency.

Safety equipment may not be used for the normal shutdown of the device.

Always be prepared for accidents or fire!

Keep First-Aid equipment (First-Aid kit, eye wash bottle, etc.) and fire extinguishers within reach.

Personnel must be familiar with the handling and location of safety, accident reporting, First-Aid and escape equipment. This ensures that personnel receive the best possible aid in case of accident and is the best way to prevent danger.

1.10 EMERGENCY-OFF switches

The device is used in a plant and does not have dedicated controller. The user must ensure that EMERGENCY-OFF- switches are installed in compliance with the applicable accident prevention

regulations. The user must inform the operating personnel about the position of and how to operate the EMERGENCY-OFF- switches, and this must be documented.

1.11 Plant control

The device is used in a plant and does not have dedicated controller. The user must ensure that the device is integrated in the plant control in compliance with the applicable accident prevention regulations.

Note the following in relation to this:

- The plant control must disconnect all connecting cables in the event of a power failure. After the power supply is restored, the device may not make any uncontrolled movements.
- Device safety equipment must be integrated in the plant control.

2 General

2.1 Liability and warranty

We have taken our existing experience and results into consideration in providing all information and instructions for the operation, servicing and cleaning of the device to the best of our knowledge.

Subject to technical modification in the interests of enhancement of the device described in these Operating/Installation Instructions.

Translations are also provided to the best of one's knowledge. We cannot accept responsibility for errors in translation. The supplied German version of the Operating Instructions remains authoritative.

Text and graphical descriptions do not necessarily correspond to the scope of supply. The drawings and graphics are not drawn 1:1.

These Operating/Installation Instructions must be read through carefully before the device is put into operation.

The manufacturer does not accept responsibility for damage and disruptions caused by failure to observe the Operating/Installation Instructions.

It is forbidden to pass these Operating/Installation Instructions on to third parties and will result in liability for damages.

2.1.1 Warranty

A warranty with the following scope is provided for this device:

All such parts as prove to be unfit for use or whose fitness for use is greatly compromised within 24 months for one-shift, 12 months for two-shift and 6 months for three-shift operation since handover to the purchaser for a cause predating handover – in particular faulty design, poor manufacture or bad materials – will be repaired or a replacement supplied at our discretion free of charge.

The warranty takes the form of replacement or repair of the device or individual parts thereof, at our discretion. Expenses hereby incurred (transport, toll, work or material costs) are borne by us, unless the expenses increase because the device was subsequently brought to a location other than the customer's location. These extra expenses are the customer's/purchaser's concern.

We provide no warranty for damage caused exclusively or partly by the following:

improper or unsuitable use, incorrect installation and/or putting into operation, natural wear and tear, incorrect handling and/or servicing, unsuitable coating substances, substitute materials and/or chemical, electrical and/or physical effects, unless we are responsible for them.

This declaration does not affect statutory rights or the contractual rights stemming from our general terms and conditions of business.

2.1.2 Wearing parts, lifetime warranty

Wearing parts are all parts that come into direct contact with the spray material and/or are subject to wear and tear on account of their function (e.g. nozzles, needles, air caps, seals, O-rings, sealing screws, pistons, etc.). Such parts are excluded from guarantee and defect claims insofar as they are based on wear and tear. The replacement of a part does not extend the warranty period of the device.

2.2 Spare parts

Only use original spare parts from the manufacturer.

! IMPORTANT!

The use of incorrect or faulty spare parts from other manufacturers may damage the device. If spare parts other than original spare parts from the manufacturer or spare parts not purchased from the manufacturer are used nevertheless, all commitments entered into by the manufacturer or its distributors, such as warranties, service contracts, etc., will lapse without advance notice.

2.3 Copyright

These Operating/Installation Instructions must be treated as confidential. They must only be used by duly authorised persons. They may only be passed on to third parties with the written consent of the manufacturer.

All documents are protected by copyright law.

The circulation and reproduction of documents, in whole or in excerpts, the use and disclosure of their content are not permitted, unless expressly allowed. Breaches may lead to prosecution and will result in liability for damages.

We reserve all rights to exercise industrial property rights.

3 Functional description

The extrusion valve **MMDV/MV LV/KV** is a pneumatically controlled valve for application of fluids as f.i. glues, adhesives, fats, colours, oils etc. The needlepiston receives alternately air pressure. When control air is switched off, a spring close the needle into the nozzle. The supply of fluid is to be obtained via pressure tank or pump. The MMDV/MV LV/KV has an extrusion jet (without atomizing air).

4 Installation and opening operations

The MMDV/MV LV/KV valve can be installed in any position. Vibrations of the valve caused by fast intermittent cycles require solid and massive installation. For solid attachment the valve body (2.0) is equipped with two holes (\varnothing 5,2 mm). Vibration of the equipped machine to the valve should be limited as far as possible.

4.1 Hose connection

Connect hoses (not included) for control air and material as follows:

1. Hose for control air to connection M5 (draw.-no.: 21.00)
2. Hose for material to connection 1/4" (21.20)

4.2 Operating instructions

CAUTION !



Never point the spray jet against persons. Wearing eye protection is strongly recommended. Spraying procedures cause noises depending on the used pressure. If necessary, wearing of ear protection is recommend.



WARNING !

Danger caused by combustible and noxious spraying material. Safety instructions on fluid pot and material data of fluid manufacturer must definitely be observed.

The extrusion valve **MMDV/MV LV/KV** is working with a control air pressure of 5-6 bar and material pressures up to 30 bar. If high material pressures are required, please observe in any case the safety regulations of the employee's compensation departments.

The valve can apply the fluid in contact as well as in non-contact to the surface. Intermittend use as well as continuous use is possible.

The travel of needle is giving way to fluid as adjusted by the regulating knob (9.12). Turning this knob in

anticlockwise turn : more fluid
clockwise turn : less fluid

One revolution of regulating knob (9.12) gives 0,5 mm more or less stroke. Maximum stroke is 6 mm. Do not over-tight the regulating knob. In this case the o-ring (9.32) can't seal the lock (9.22).

IMPORTANT !



The maximum fluid outlet is already reached, when no further ratchets are noticeable. Do not Turn the regulating knob (9.12) in anticlockwise turn any further.

IMPORTANT !



To avoid damages to nozzle and needle, adjust decrease of fluid flow (turning regulating knob 9.12 clockwise) only when fluid is emitted from the nozzle. This is the only way to observe the steady reduction of fluid flow until an absolute stop of fluid. Going on to turn the regulating knob clockwise would at once push the needle into the nozzle to such an extent that both parts could be damaged.

It is harmless to leave fluid within the valve (no connection to outside air), if system stays under pressure.

5 Repair and Maintenance

Before starting maintenance or repair work, ensure that all air operated tools are disconnected from the air supply.



WARNING !

Danger caused by combustible and noxious spraying material. Safety instructions on fluid can and material data of fluid manufacturer must definitely be observed.



WARNING !

Before opening the spray valve it has to be disconnected from the air and fluid supply. Otherwise ejected elements can cause danger.

The extrusion valves of series **MMDV/MV LV/KV** are high precision tools. Always keep clean and observe minimum instructions to maintain a long and useful life of valve. We recommend lubricating moveable parts regularly, and greasing threads, especially the nozzle threads, when replacing or cleaning the nozzle.

It is recommended to use clean and filtered application fluids only. Control air should be slightly oiled.

5.1 Cleaning

To clean valve, spray solvent until pure solvent leaves the nozzle. Do not submerge entire valve in solvent. At longer working interruptions it is advisable to clean needle (7.10), retainer (6.10) and nozzle (2.10) by putting these parts only into solvent. If necessary use soft brush. Moving parts and threads should always be greased slightly. The valve should be cleaned using an appropriate thinner. To clean small drill holes, use our special nozzle cleaning needles.

5.2 Possible case of failure: Needle sticks

- 1) Check, if current on solenoid valve (slight click noise).
- 2) Check, if sufficient control air pressure is supplied (5 - 6 bar).
- 3) Check, if o-ring (6.20) or o-ring (7.40) are defect.
- 4) Check, if needle (7.10) is stucked together within retainer (6.10).
- 5) Check, if minimum of travel of needle is set.

5.3 Changing needle (7.10) and nozzle (2.10)

Unscrew ratchet assembly (9.02). Unscrew nozzle (2.10) with wrench SW 10. Take out needle spring (8.10) and pull out needle (7.10) on back side of needle piston by using a flat tong. Re-assemble new parts in reverse order slightly greased. It is not recommended to use old needles and nozzles because even slightly damaged needle shafts would immediately cause leakage in gaskets.

5.4 Changing retainer (6.00)



IMPORTANT !

Do not use metallical aid to remove and insert gaskets and gasket seats !
Gaskets and gaskets seats can be damaged.

Unscrew ratchet assembly (9.02). Unscrew nozzle (2.10) with wrench SW 10. Take out needle spring (8.10) and pull out needle (7.10) on back side of needle piston by using a flat tong. Then using a screwdriver loosen retainer (6.00) till end of thread. As retainer can not go through the thread of valve body (4.10) by itself because of o-ring (5.30), it has to be carefully pushed through be means of a thin metal sheet of 0,5 - 1,0 mm placed between gun body recess and retainer. After passing thread retainer is accessible for taking out of housing.

5.5 Replacing new gaskets



IMPORTANT !

Do not use metallical aid to remove and insert gaskets and gasket seats !
Gaskets and gaskets seats can be damaged.

In case a new retainer (6.00) is not available to be replaced as a complete unit, the used retainer has to be cleaned thoroughly especially the o-ring groove and seats. These should also be greased slightly. O-ring (6.20) is to be placed first into ground of the rear retainer bore. O-ring (5.30) then into the outer groove. Insert the gasket (5.50) into the front retainer bore. The gasket (5.50) is not symmetrical. The somewhat wider opening must be positioned to point to the front of spray valve i.e. after assembling retainer in direction "nozzle". Completed retainer (6.00) slightly greased then is put back into valve body (4.10) and without turning movement by means of a screw driver is to be carefully pushed through valve body thread observing outer o-ring (5.30). Lastly screw retainer into housing thread (tighten only slightly).

When inserting o-rings and gaskets, do not use any sharp or pointed matallic implements. Mainly the gasket as a very precise and sensitive component is not able to stand impacts.

Technical alterations reserved. February 2003.

Distributor in Baltic: Lithuania, Latvia, Estonia
PAKARTE.COM (located in Estonia)
e-mail: pakarte@pakarte.com

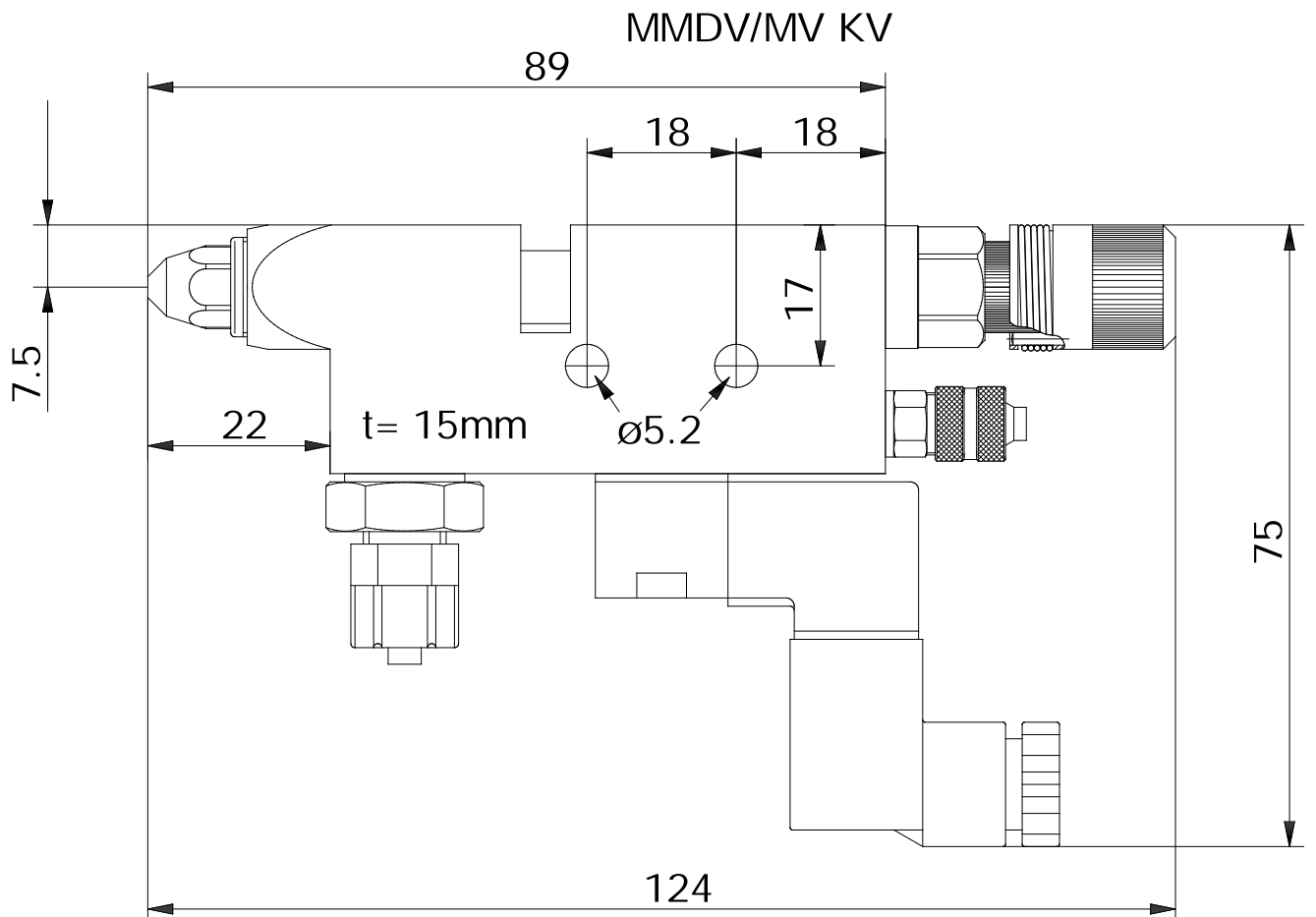
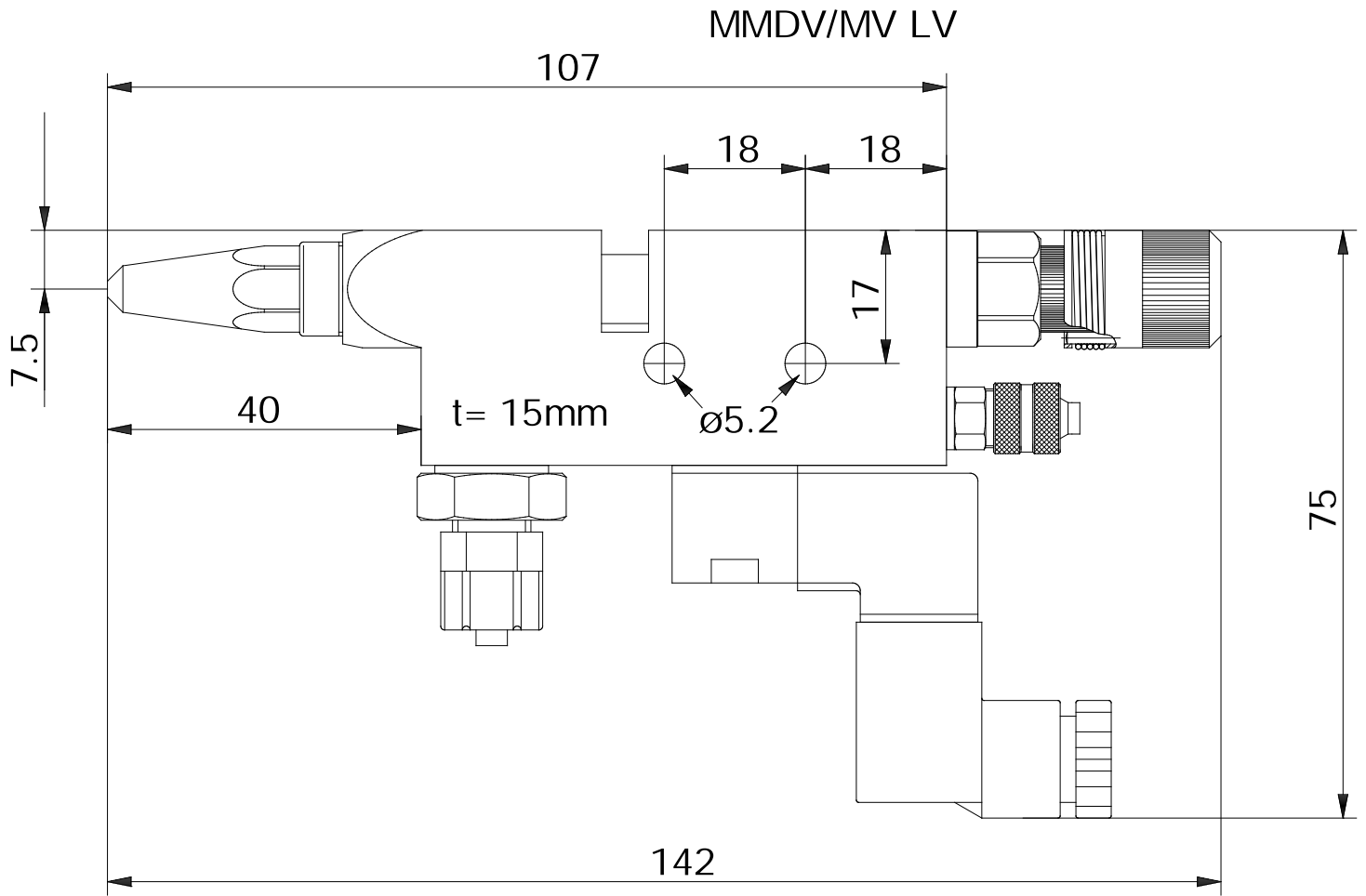

Distributor in Baltic: Lithuania, Latvia, Estonia
 PAKARTE.COM (located in Estonia)
 e-mail: pakarte@pakarte.com

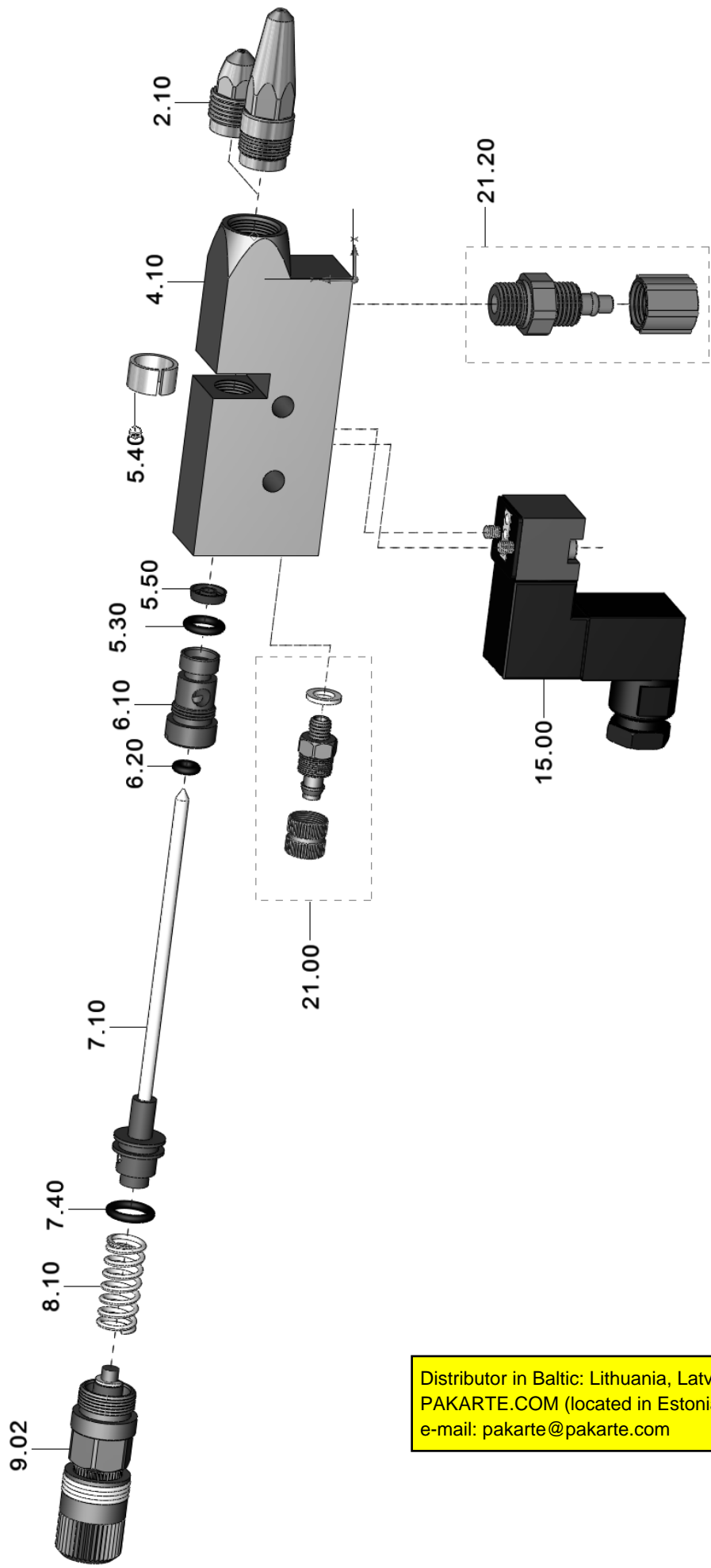

Distributor in Baltic: Lithuania, Latvia, Estonia
PAKARTE.COM (located in Estonia)
e-mail: pakarte@pakarte.com

6 Sparepartslist

draw.-no.	part-no.	Qty.	description
2.10	*	1	Nozzle, stainless steel
4.10	510036	1	valve body MMDV/MV, complete
5.00	640102	1	gasket set
5.30	640021	1	o-ring 6,07 x 1,78 / Viton®
5.40	640101	1	protecting cover, Ø 10 x 6mm
5.50	640004	1	gasket (Variseal 2,65 x 2,0 x 2,8)
6.00	810014	1	retainer, complete, 11 x 21mm, Viton®
6.10	810013	1	retainer, Drm. 11 x 21mm
6.20	640026	1	o-ring 2,90 x 1,78 / Viton®
7.10	*	1	needle, complete
7.40	640001	1	o-ring 7,65 x 1,78 / Viton®
8.10	820024	1	spring 1,2 x 21,5mm
9.02	900008	1	ratchet assembly, Ø 15 x min. 45mm
9.12	610093	1	Regulating knob Ø 15 x 45mm
9.22	220104	1	lock screw, wrench size 13 x 26mm
9.32	640027	1	o-ring 4,47 x 1,78 / Viton®
9.42	320022	1	straight pin DIN 6325 1,5x8
9.52	820000	1	spring 0,8 x 8,5 mm
9.62	620017	1	circlip DIN 6799 RA 2,3
9.72	320098	1	stop unit core, 6,6 x 4 x 5mm
15.00	*	1	solenoid valve, with plug
21.00	220089	1	pipe fitting, straight, wrench size 8 x 19mm
21.20	220022	1	pipe fitting, straight, 1/8" - 6/4 plastic

* Please find part-numbers on next pages.

When ordering needles and nozzles, please specify dimension.

Available dimensions: 0,2 / 0,3 / 0,4 / 0,5 / 0,6 / 0,7 / 0,8 / 1,0 / 1,2 / 1,5 / 2,0 mm Ø

6.1 Part-numbers for nozzles, needles and solenoid valves

nozzle, LV, stainless steel (2.10)	
draw.-no.	description
210132	nozzle, LV, 0,2 mm, stainless steel
210133	nozzle, LV, 0,3 mm, stainless steel
210134	nozzle, LV, 0,4 mm, stainless steel
210102	nozzle, LV, 0,5 mm, stainless steel
210136	nozzle, LV, 0,6 mm, stainless steel
210137	nozzle, LV, 0,7 mm, stainless steel
210138	nozzle, LV, 0,8 mm, stainless steel
210139	nozzle, LV, 1,0 mm, stainless steel
210140	nozzle, LV, 1,2 mm, stainless steel
210141	nozzle, LV, 1,5 mm, stainless steel
210142	nozzle, LV, 2,0 mm, stainless steel

nozzle, KV, stainless steel (2.10)	
draw.-no.	description
210143	nozzle, KV, 0,2 mm, stainless steel
210144	nozzle, KV, 0,3 mm, stainless steel
210145	nozzle, KV, 0,4 mm, stainless steel
210146	nozzle, KV, 0,5 mm, stainless steel
210147	nozzle, KV, 0,6 mm, stainless steel
210148	nozzle, KV, 0,7 mm, stainless steel
210149	nozzle, KV, 0,8 mm, stainless steel
210150	nozzle, KV, 1,0 mm, stainless steel
210151	nozzle, KV, 1,2 mm, stainless steel
210152	nozzle, KV, 1,5 mm, stainless steel
210153	nozzle, KV, 2,0 mm, stainless steel

needle, LV, complete (7.10)	
Artikel-Nr.	Bezeichnung
110221	needle, LV 0,2/0,3mm, complete
110222	needle, LV 0,4mm, complete
110223	needle, LV 0,5mm, complete
110224	needle, LV 0,6/0,7mm, complete
110225	needle, LV 0,8/1,0mm, complete
110227	needle, LV 1,2mm, complete
110228	needle, LV 1,5mm, complete
110229	needle, LV 2,0mm, complete

needle, LV, complete (7.10)	
Artikel-Nr.	Bezeichnung
110230	needle, KV 0,2/0,3mm, complete
110231	needle, KV 0,4mm, complete
110232	needle, KV 0,5mm, complete
110233	needle, KV 0,6/0,7mm, complete
110234	needle, KV 0,8/1,0mm, complete
110235	needle, KV 1,2mm, complete
110236	needle, KV 1,5mm, complete
110237	needle, KV 2,0mm, complete

solenoid valve 3/2 way, with plug (15.00)	
Artikel-Nr.	Bezeichnung
150104	solenoid valve 3/2 way 24 V/DC/2W with plug
150019	solenoid valve 3/2 way 110V/50Hz/1,5W, with plug
150121	soleniod valve 3/2 way 230V/50Hz/1W with plug

7 Technical data

measurements:

LV-version = approx. 142mm x 15mm x 75mm
KV-version = approx. 124mm x 15mm x 75mm
weight = 265 g
control air pressure = 5 - 6 bar
material pressure = max. 30 bar
gaskets = Viton

Special design on request. Technical alterations reserved. March 2013.

8 Manufacturer Declaration

The extrusion valves **MMDV/MV LV/KV** are constructed and produced by **ALFRED SCHÜTZE Apparatbau GmbH, Zeppelinstraße 2, 28844 Weyhe-Dreye – Germany** in accordance with the guidelines and standards of DIN EN 292. This spray valve can be combined with other modules or machines, which comply to DIN EN 292, without limiting the conformity.

place
Bremen

date
14.03.2013

signature of manufacturer

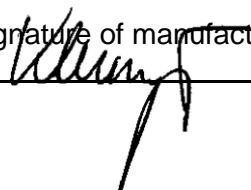

Distributor in Baltic: Lithuania, Latvia, Estonia
PAKARTE.COM (located in Estonia)
e-mail: pakarte@pakarte.com